

# Carbon neutrality comes from reducing CO<sub>2</sub>

# emissions through long service life products

## What "HIGH PRODUCTIVITY" means to CKD

Lower productivity will result in loss. In addition, parts requiring maintenance will be wasted. We believe that achieving high productivity without maintenance leads to carbon neutrality. Our HP Series focuses on the manufacturing principles of such component manufacturers. To improve productivity in places with high usage frequency and high-stress environments, the series serves to create a "production facility with no downtime" and "achieves stable operation" with products that have an unprecedented long service life.

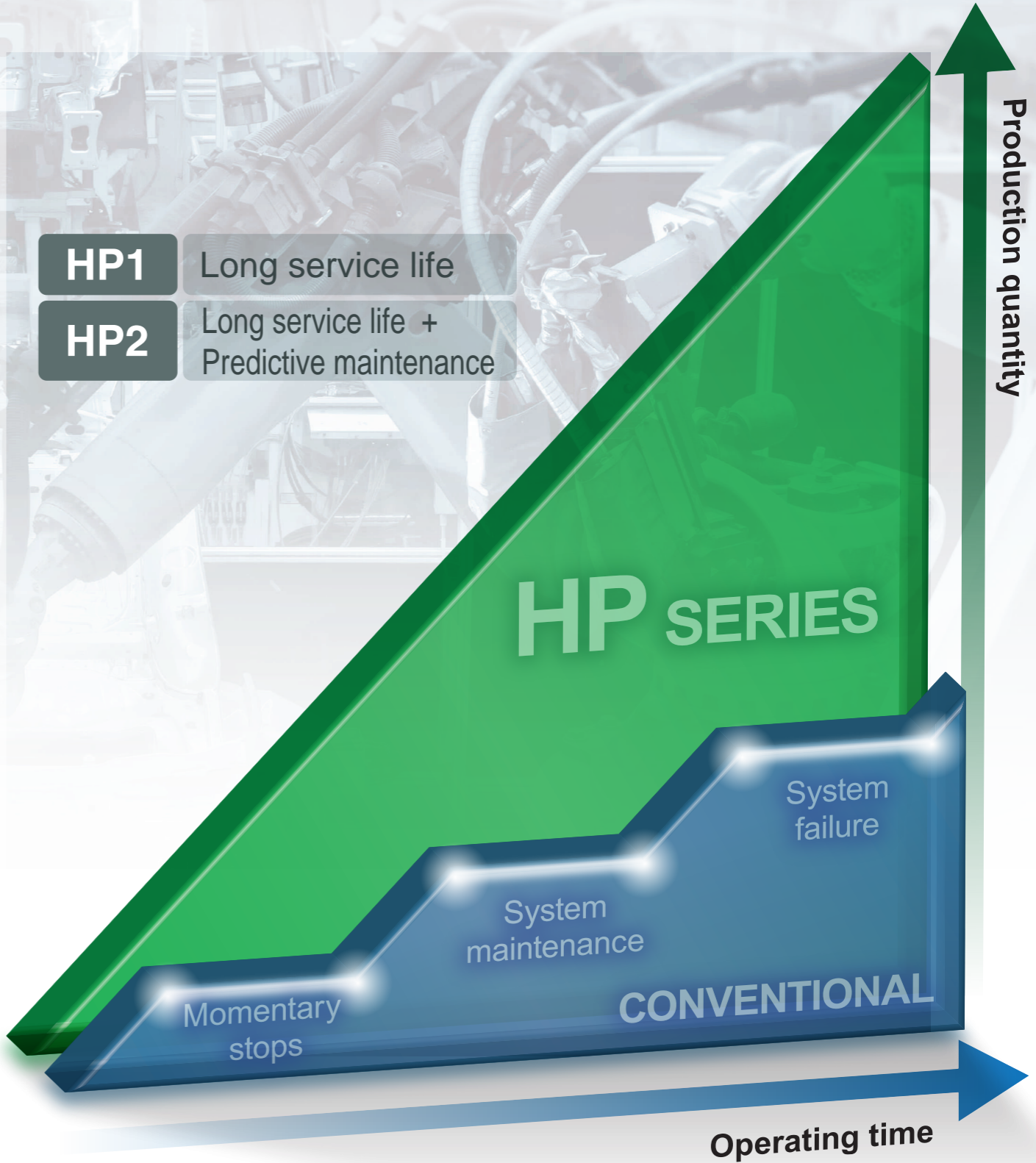

## Carbon neutral

- Reduced exterior leakage
- Energy saving coil option (0.1 W)
- Reclaimed resin used

# Plug-in valve

## Easy to use

- Plug-in structure
- IP65/67
- Improved maintainability (built-in gasket)

## High reliability

- Stable operation even with ultra dry air
- High durability of 120 million operations or more (twice that of conventional models)
- No unexplained stoppages

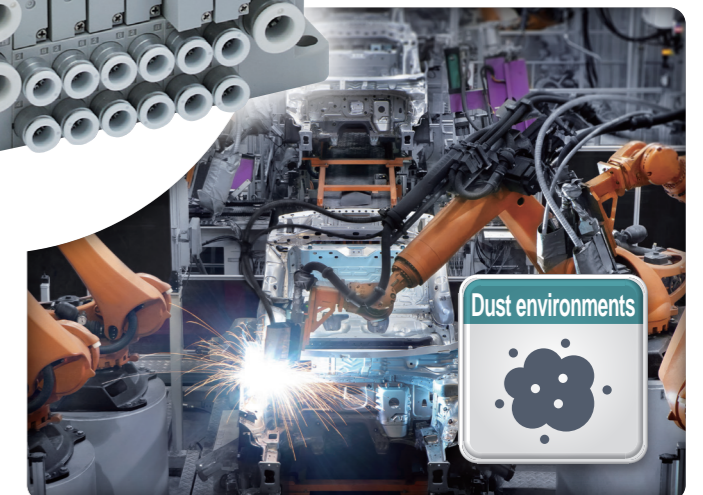
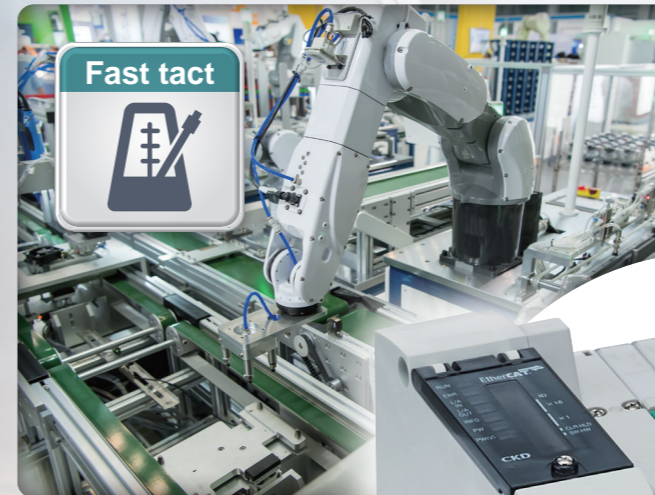

## Plugs into various devices

Carbon neutrality and IoT contribute to the visualization of equipment and the elimination of control panels.

Waterproof, robust, high-performance, and remote I/O-compatible FA system is a key part of the global model.

Pilot operated 3, 5-port solenoid valve, plug-in block manifold

# TVG Series

# Carbon neutral

# High reliability

## Reduces air leakage

Thoroughly improved valve parts that are prone to air leakage.

This plug-in valve is the culmination of CKD's commitment to sustained energy savings even with long-term use.

	Air leakage cause	Commitment to TVG
1	The deterioration of rigidity of resin materials due to moisture in the atmosphere, including during water adhesion, transportation, and storage.	Sealing design to withstand aging and special resin material to reduce air leakage.
2	Coil heating and changes in the ambient temperature cause repeated thermal stress, reducing the rigidity of resin materials.	Coil temperature rise is reduced. Air leakage is reduced with a special resin material and sealing design resistant to aging.
3	Wear of the spool packing causes supply air to run into the exhaust port.	Spool packing and special treatment on the body interior reduce wear.

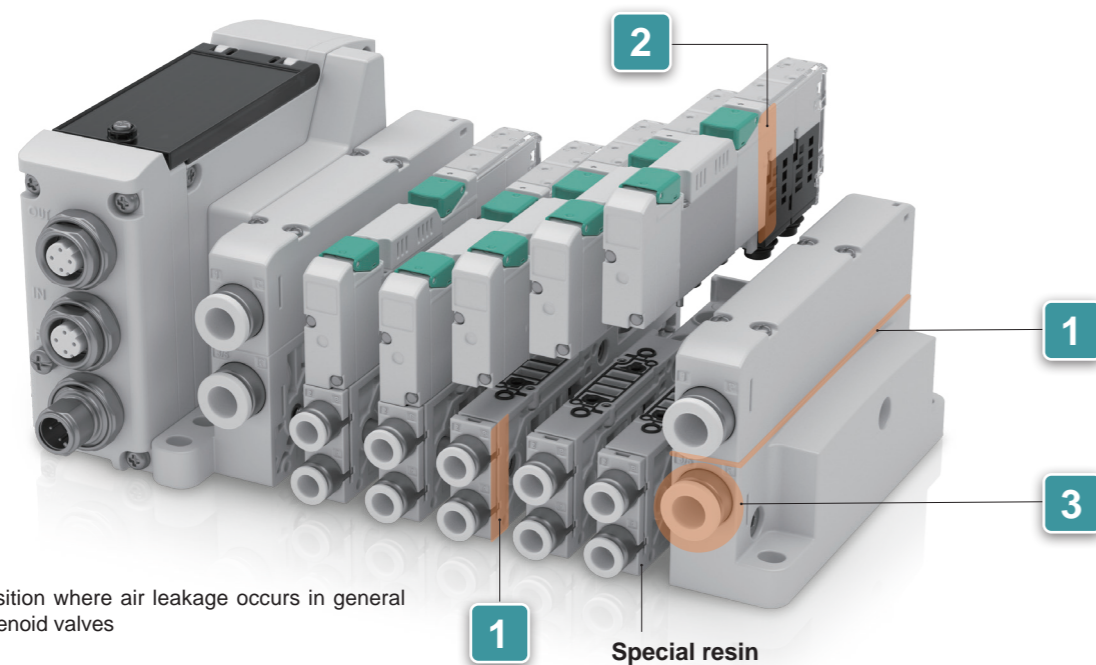

## Strives for stable operation

The TVG Series has been developed to optimize the sliding parts and achieves durability of 120 million cycles or more\*. Stable operation due to low friction supports the reliable operation of the actuator, realizing stable operation of equipment and reduction in quality fluctuations.

### Low friction/long service life

The superb sliding mechanism of the main valve realizes low friction and long service life. The elastic seal withstands 120 million cycles. Achieves both long service life and low air leakage.

Durability count 120 million operations or more\*

\*Subject to CKD prescribed conditions.

Elastic sealing  
**2x**  
conventional

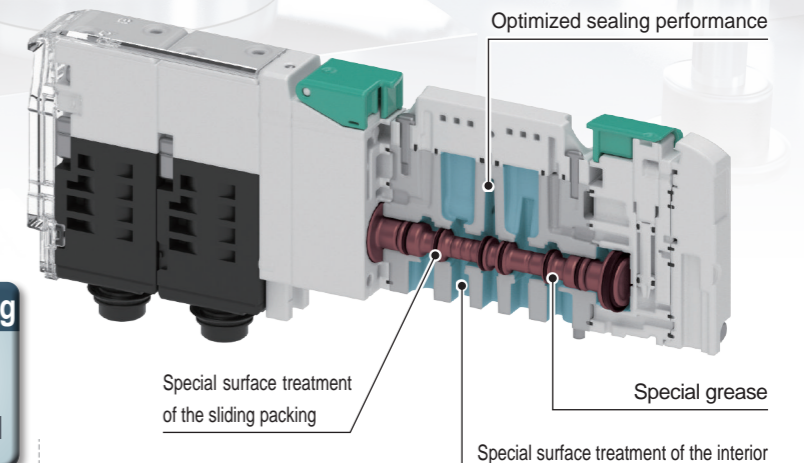
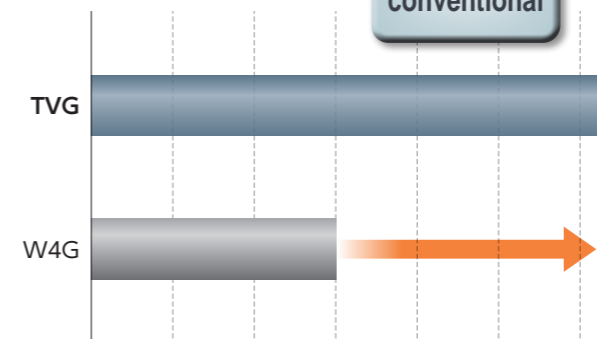

### Improved responsivity after startup

Smooth start even after time off. Effective for Monday morning troubles and unexplained stoppages as well.

### Special grease used

Lubrication effect continues even with ultra dry air.

### Internal pilot filter equipped as standard

Improved operation stability.

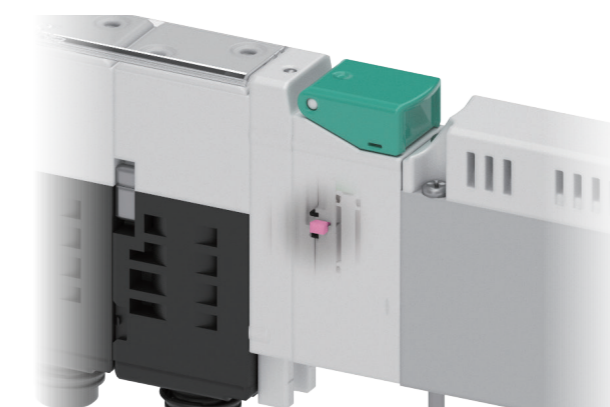

### Prevents problems with foreign matter

Port P (air supply) equipped with filter as standard.



### Exhaust check valve (option) PAT.P

Retrofitting is possible even after installation.

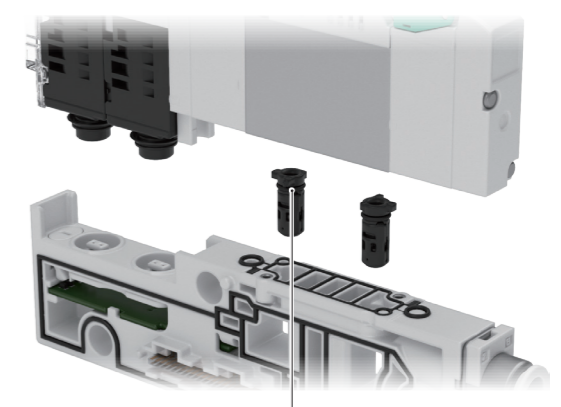

The outer O-ring prevents small amounts of air from entering. Prevents compact actuators from malfunctioning.

### Also compatible with global standards



## Coil performance improved

### Continuous energizing possible (low exoergic/energy circuit)

Uses a new coil actuator.

### Power consumption

0.1 W (With low exoergic/energy circuit)

0.4 W (Standard products)

## Reduced power consumption

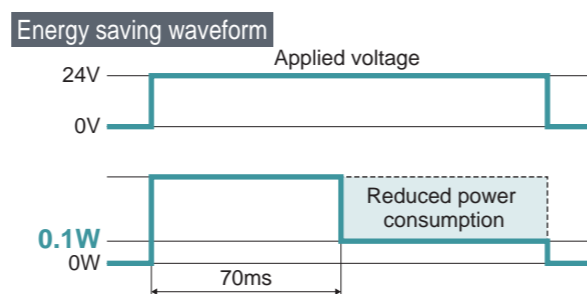

## Uses materials with reduced environmental load

### Biomass plastic

Protective cover\*1 is made of plant-derived biomass plastic.

\*1. The protective cover cannot be closed when manual operation is enabled, making it ideal for preventing forgotten manual operation.



### Recycled material resin

The use of recycled resin contributes to reducing the environmental load

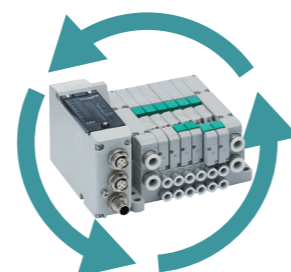

# Easy to use

## Plug-in valve with excellent workability

### 5 Positioning support as standard PAT.P

A "positioning support" that allows anyone to easily position the valve and base is provided as standard.

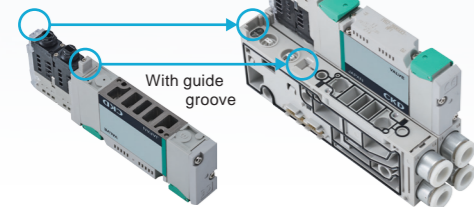

### 6 Easy-to-assemble plug-in connection PAT.P

Actuator additions are wired complete by plug-ins.

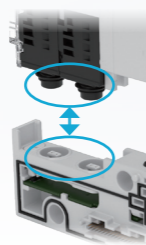

### 7 Connections that make it easy to adjust the number of stations

Internal wiring is completed at the same time as the manifold assembly.

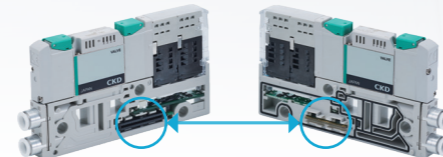

### 8 Screw dropout prevention as standard



### 9 No parts dropped out

Gasket is built into the base.



Tag plate mounting holes provided as standard

- 1a Shutter closed
- 1b Shutter open
- 2a Chuck closed
- 2b Chuck open

\*The tag plate must be prepared by the customer.

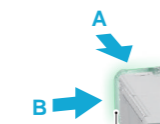

Operation lamp visible from 2 directions

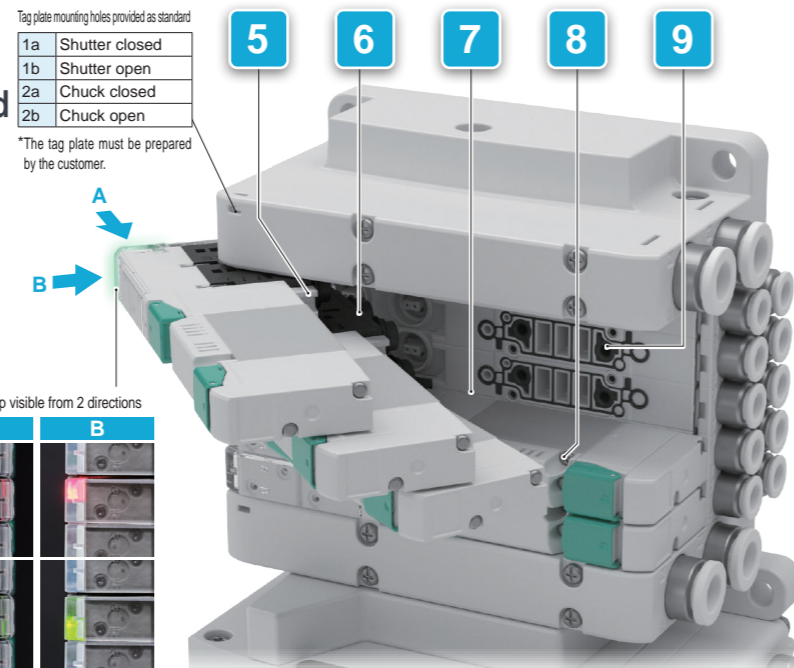
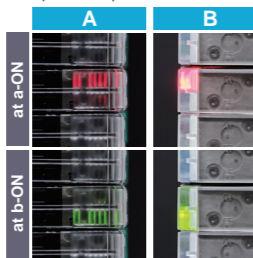

## Improved environmental performance

### IP65/IP67 (dust/water-jet proof) for tough use

IP6\*: No inflow of dust

IP\*5: No harmful effects by water jets from any direction

IP\*7: Prevents water from entering in amounts that would cause harmful effects even if temporarily submerged in water for a specified pressure and time

\*TVG can be used in both IP67 and 65 environments. Refer to page 144 for IP performance.

### Prevention of coil corrosion

Molded coil specification that is resistant to corrosion. Prevents water from adhering during use and rust due to moisture during transportation and storage.

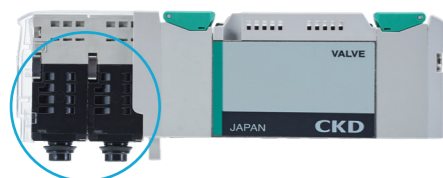

# IP65/67

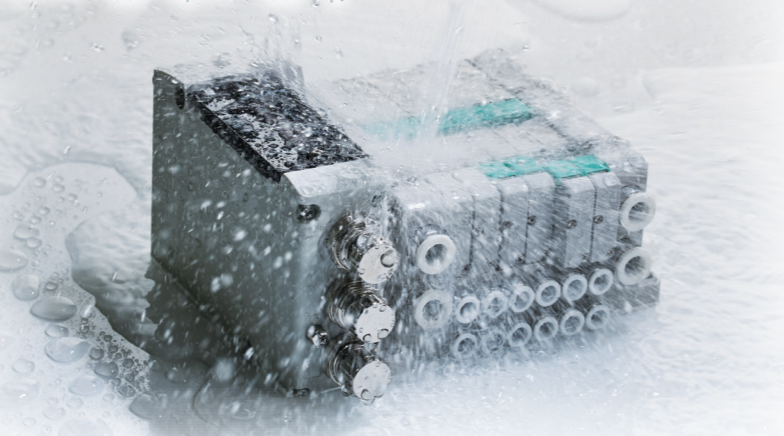

### P4 Series for rechargeable battery manufacturing equipment

Restricted specifications for materials and surface treatments inappropriate for rechargeable battery manufacturing processes.

## Valve width of 10mm, 15mm are supported

Our first 10 mm wide plug-in valve!

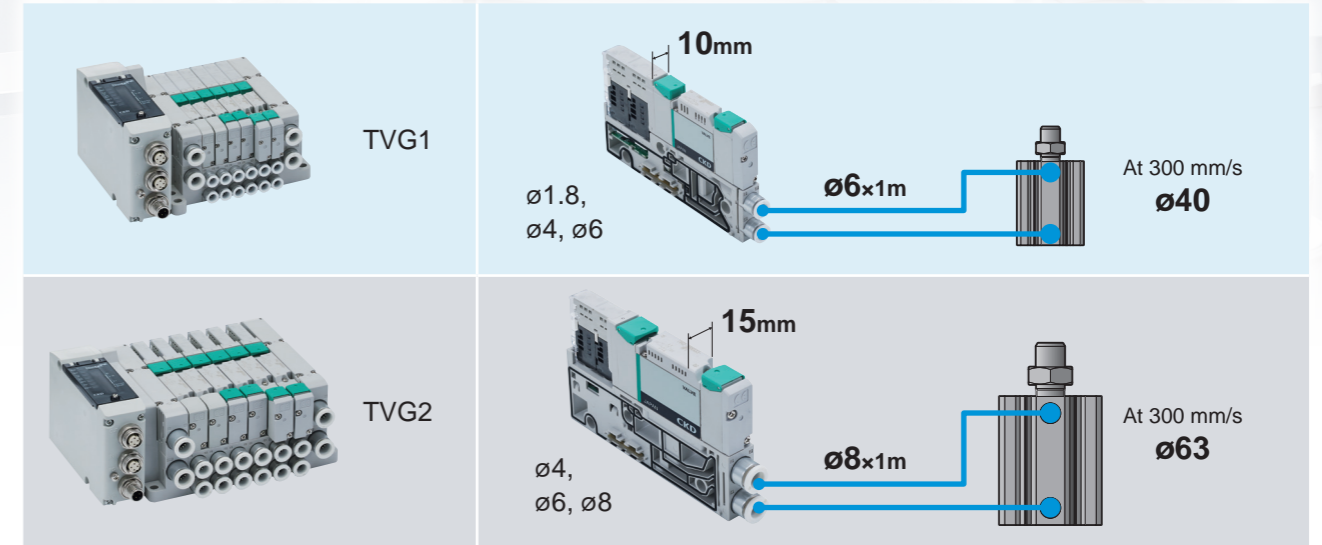

## Compatible with various communications

Output only	Solenoid valve size	Supported communication	Max. number of points	Max. number of solenoid valves
	TVG1, TVG2	EtherNet/IP*1 DeviceNet, EtherCAT*1, CC-Link IE TSN, CC-Link IE Field*1, CC-Link IE Field Basic*1, CC-LINK, PROFINET*1, IO-Link*1, IO-Link Wireless*1	Solenoid: 32 points	TVG1:24 stations TVG2:24 stations

\*1. Solenoid valve ON count function.

With remote I/O	Solenoid valve size	Supported communication	Max. number of points	Max. number of solenoid valves
	TVG1, TVG2	EtherNet/IP, EtherCAT, IO-Link*2	Solenoid: 32 points I/O:4096-point*3	TVG1:24 stations TVG2:24 stations

\*2. As a IO-Link master. Solenoid valve communication is EtherNet/IP and EtherCAT.

\*3. Solenoid points 32 are included in I/O point count 4096.

\*4. Remote I/O must be prepared separately. Refer to Remote I/O RT Series (CC-1557A) for details.

# Application (IO-Link Wireless)

Industry's first

## Open network IO-Link Wireless compatible solenoid valve\*1

Uninterrupted wireless, usable for control. One billionth error rate. \*2 Enables wireless connection of solenoid valve with PLC of various communications via IO-Link Wireless master.

Item	Wireless LAN	Bluetooth	ZigBee	IO-Link Wireless
Standards	IEEE802.11b	IEEE802.15.1	IEEE802.15.4	<b>IEEE802.15.1</b>
Frequency	2.4GHz	2.4GHz	2.4GHz	<b>2.4GHz</b>
Communication distance	Up to 100m	Up to 10m	Up to 100m	<b>Up to 10m</b>
Transmission bit rate	11Mbps	1Mbps	250kbps	<b>21kbps</b>
Connection nodes	32	7	128	<b>40</b>
Delay time	50ms	10 to 30ms	100ms	<b>5ms</b>
Reliability	Low	Low	Medium	<b>High</b>

### Blacklist function

Avoids frequencies used in other wireless components. Coexistence with other wireless components is made possible.

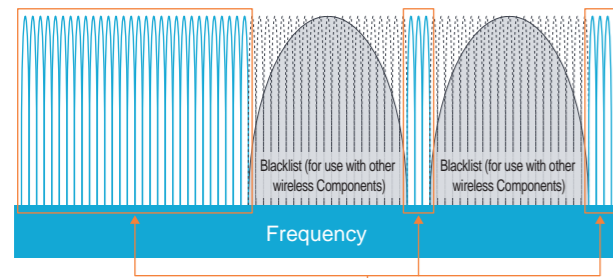

### Frequency hopping function

Retries are executed 3 times in one communication cycle by switching frequency bands.

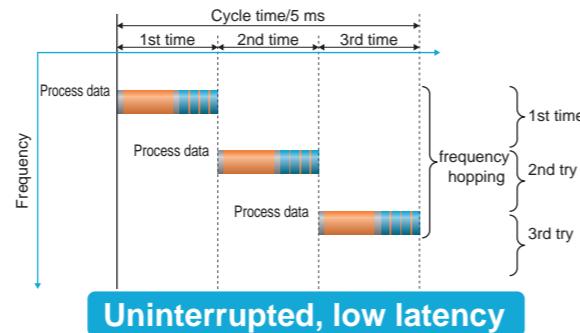

### IO-Link Wireless system configuration example

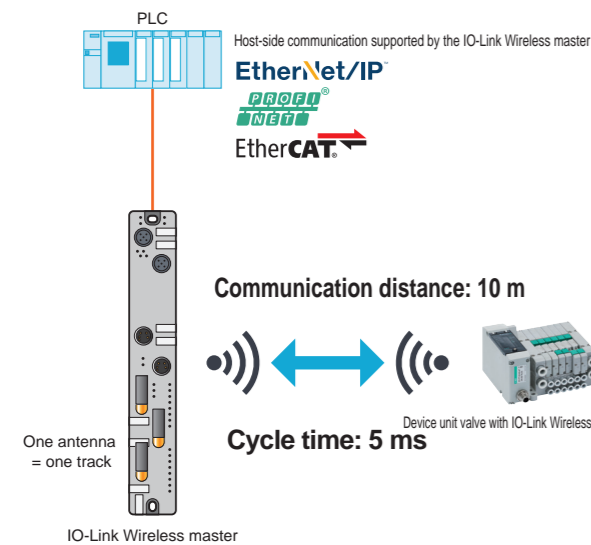

### Solenoid valve lineup with IO-Link Wireless device unit

Solenoid valve appearance	IO-Link master (1 track) number of connected units per	Cycle Time
	1 to 6 units	5ms
	7 to 8 units	10ms
	32 pts Output	

\*1. June 2023, CKD research. CKD IO-Link Wireless component compatible regions: Japan and EU.

\*2. Blacklist and frequency hopping functions provide wired-like reliability. Wireless quality for use in control.

## Assembly/Inspection (rotating table)

The solenoid valve manifold can be installed on the rotary table because the signal line is wireless. Equipment can be designed to improve workpiece positioning accuracy and accommodate a wide variety of workpieces.

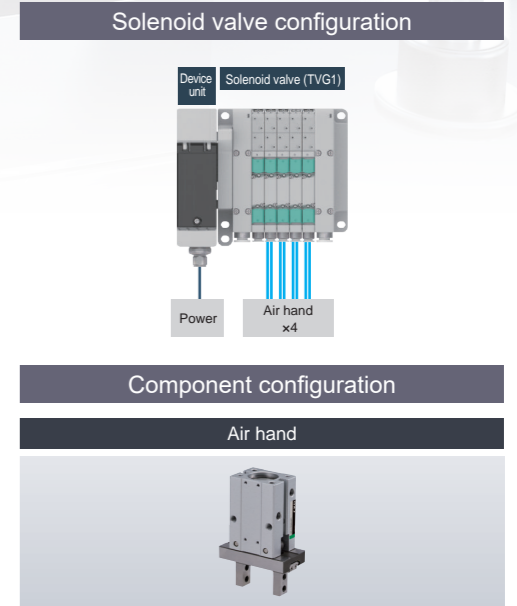
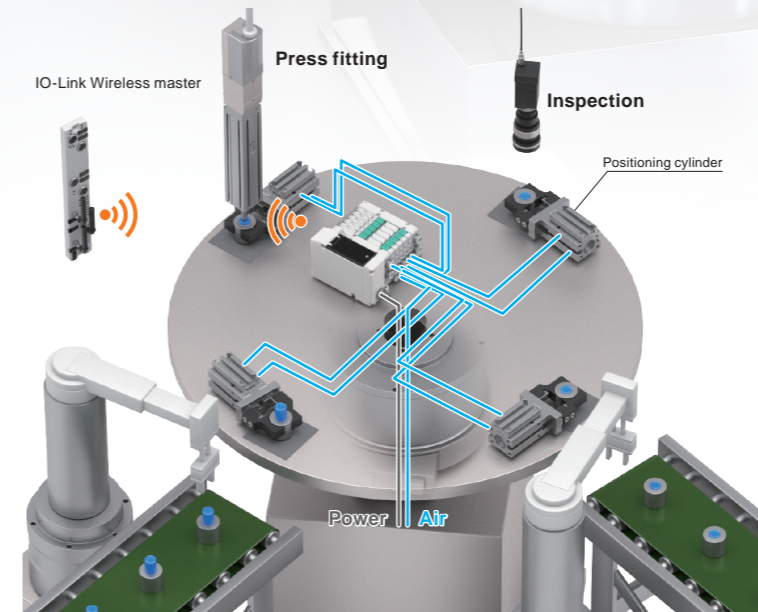

## Pallet transport

The solenoid valve for cylinder operation in the pallet is made wireless. By combining with a wireless power feed component, it is possible to hold a workpiece for a short time with air sealing even during travel.

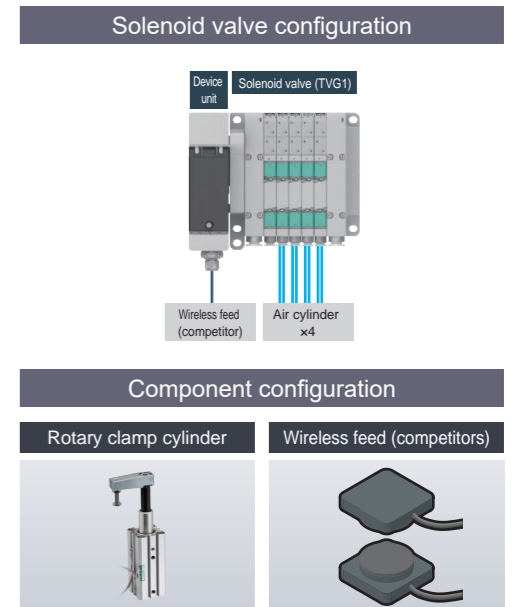
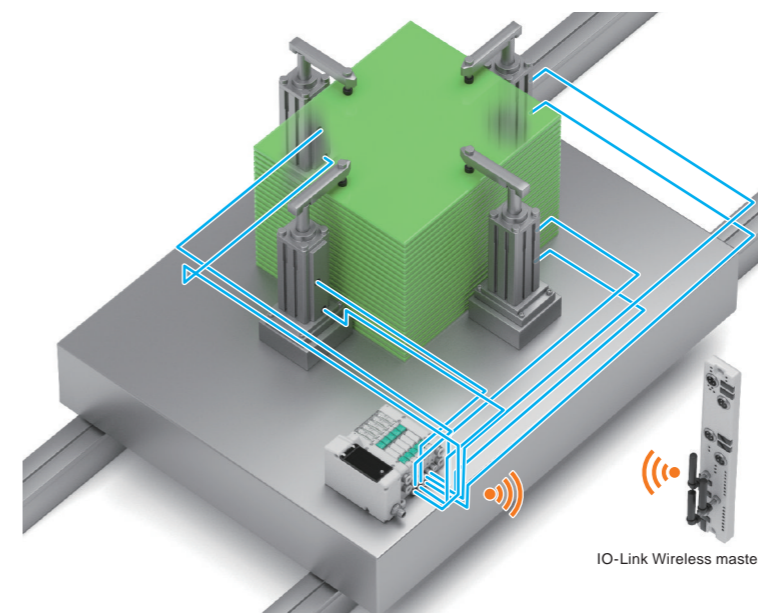

# Application

## Conveying equipment

Air piping and electrical wiring can be consolidated in mixed equipment with servomotor-driven actuators and air hands.

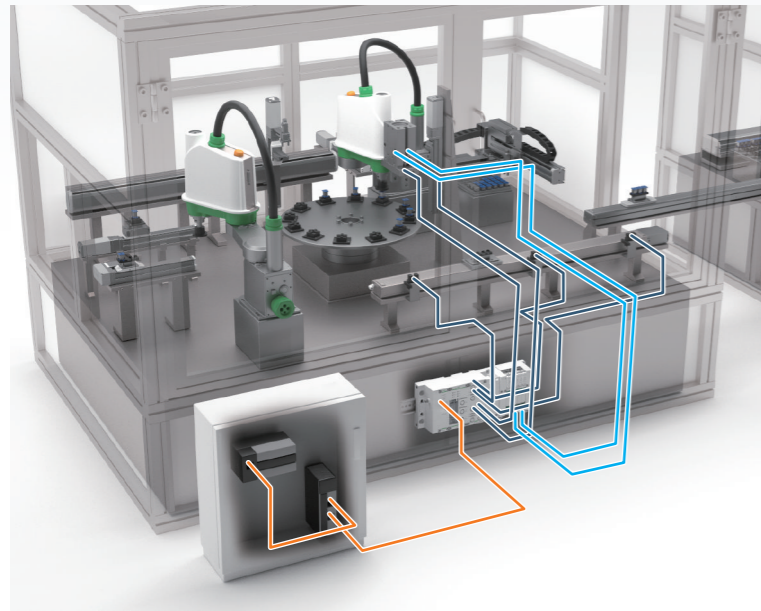

### Remote I/O configuration

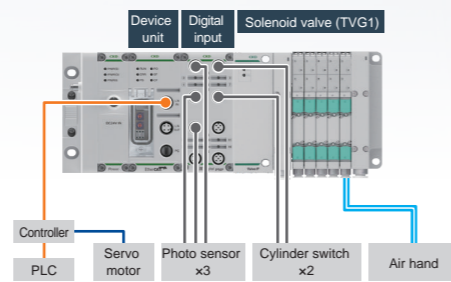

### Component configuration



## Rechargeable battery manufacturing process

Supports the rechargeable battery manufacturing process from electrode manufacturing to packaging. P4 option compatible with material restrictions and ultra dry air with dew point  $-70^{\circ}\text{C}$  available. The long service life of the non-volatile special grease contributes to the stable operation of equipment.

### Rechargeable battery option: P4

- (1) Electric circuit unit IP65/67
- (2) Flow path part Material restrictions
- (3) SUS fitting



Stable operation even at  $-70^{\circ}\text{C}$  dew point is realized by special grease adopted as standard.

Refer to Rechargeable Battery Compatible Components P4\* Series (CC-1226A) for details.

## Auto body welding

Contributes to reduced wiring of solenoid valves for cylinder drive and cylinder switch input. Only one Ethernet cable is required to complete wiring from the PLC (Programmable Logic Controller), contributing to reduction of installation space and improvement of wiring layout for devices including IO-Link devices.

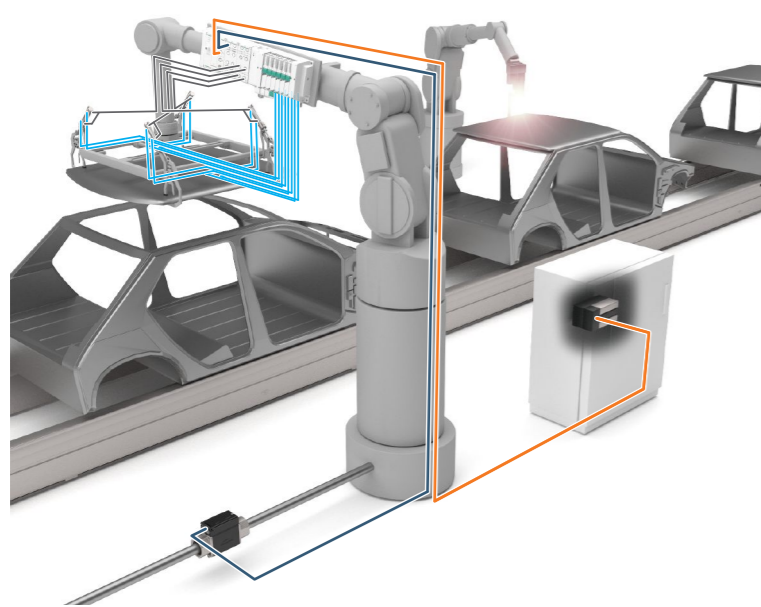

### Remote I/O configuration

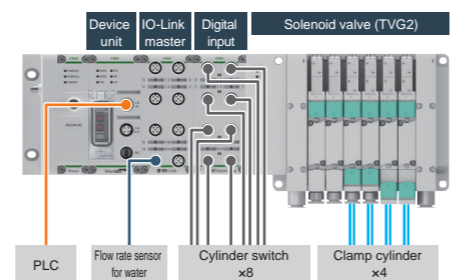

### Component configuration



## Internal pressure explosion-proof panel

Ideal for applications where solenoid valves are installed in internal explosion-proof control panels. Since there is little air leakage, the influence of pressure control inside the panel is minimized, contributing to stable operation of the equipment.

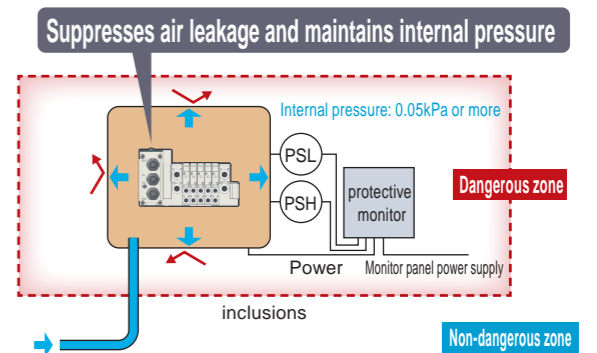
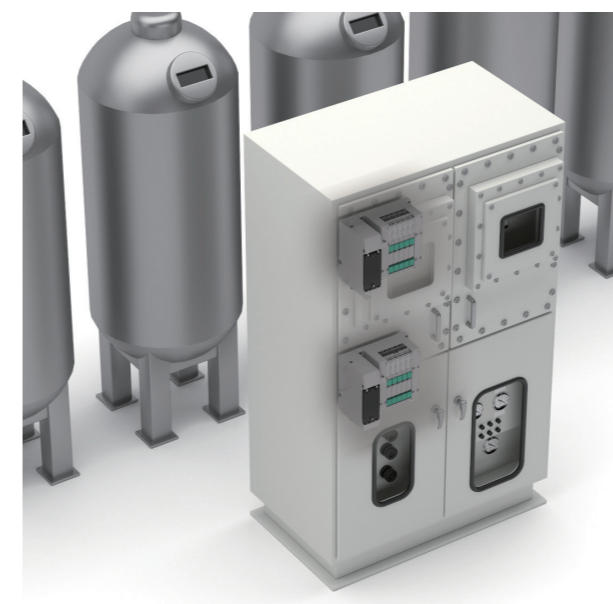

### Supports continuous energization

Energy saving coil (0.1 W) is available as an option, and it supports continuous energization, which is often required for air-operated control.

### Special resin

The special resin adopted as standard suppresses secular change and air leakage from the valve for long periods.

Explosion-proof model certification has not been obtained for discrete solenoid valves. For internal pressure and explosion-proof use, the customer must apply for and obtain a model certification. Observe JNIOHS-TR-46-3 and other standards when performing installation.